

SOT-23 Plastic-Encapsulate Transistors

MMBT4401 TRANSISTOR (NPN)

FEATURES

- Switching Transistor

MARKING:2X

MAXIMUM RATINGS (T_a=25°C unless otherwise noted)

Symbol	Parameter	Value	Unit
V _{CB0}	Collector-Base Voltage	60	V
V _{CEO}	Collector-Emitter Voltage	40	V
V _{EBO}	Emitter-Base Voltage	6	V
I _C	Collector Current	600	mA
P _C	Collector Power Dissipation	300	mW
R _{θJA}	Thermal Resistance From Junction To Ambient	417	°C/W
T _j	Junction Temperature	150	°C
T _{stg}	Storage Temperature	-55~+150	°C

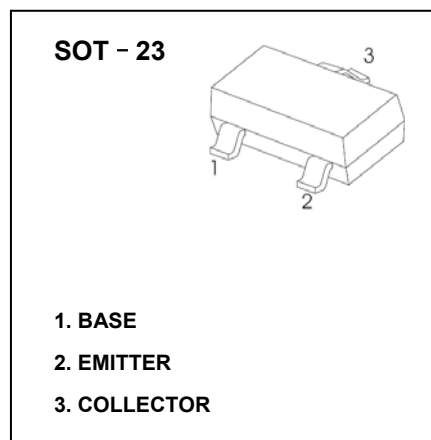

ELECTRICAL CHARACTERISTICS (T_a=25°C unless otherwise specified)

Parameter	Symbol	Test Conditions	Min	Typ	Max	Unit
Collector-base breakdown voltage	V _{(BR)CBO}	I _C =100 μA, I _E =0	60			V
Collector-emitter breakdown voltage	V _{(BR)CEO}	I _C =1mA, I _B =0	40			V
Emitter-base breakdown voltage	V _{(BR)EBO}	I _E =100 μA, I _C =0	6			V
Collector cut-off current	I _{CBO}	V _{CB} =50V, I _E =0			0.1	μA
Collector cut-off current	I _{CEX}	V _{CE} =35V, V _{EB} =0.4V			0.1	μA
Emitter cut-off current	I _{EBO}	V _{EB} =5V, I _C =0			0.1	μA
DC current gain	h _{FE1}	V _{CE} =1V, I _C =0.1mA	20			
	h _{FE2}	V _{CE} =1V, I _C =1mA	40			
	h _{FE3}	V _{CE} =1V, I _C =10mA	80			
	h _{FE4}	V _{CE} =1V, I _C =150mA	100		300	
	h _{FE5}	V _{CE} =2V, I _C =500mA	40			
Collector-emitter saturation voltage	V _{CE(sat)}	I _C =150mA, I _B =15mA			0.4	V
		I _C =500mA, I _B =50mA			0.75	V
Base-emitter saturation voltage	V _{BE(sat)}	I _C =150mA, I _B =15mA			0.95	V
		I _C =500mA, I _B =50mA			1.2	V
Transition frequency	f _T	V _{CE} =10V, I _C =20mA, f=100MHz	250			MHz
Delay time	t _d	V _{CC} =30V, V _{BE(off)} =-2V			15	ns
Rise time	t _r	I _C =150mA, I _{B1} =15mA			20	ns
Storage time	t _s	V _{CC} =30V, I _C =150mA			225	ns
Fall time	t _f	I _{B1} =I _{B2} =15mA			60	ns

Typical Characteristics

