

SOT-23 Plastic-Encapsulate Transistors

C1815 TRANSISTOR (NPN)

FEATURES

Power dissipation

MARKING : HF

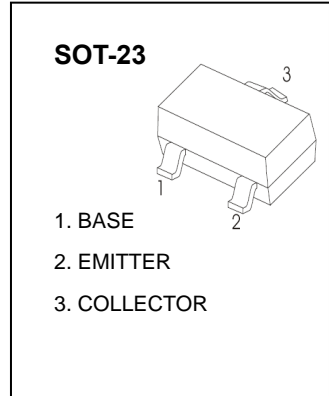

MAXIMUM RATINGS (T_a=25°C unless otherwise noted)

Symbol	Parameter	Value	Unit
V _{CBO}	Collector-Base Voltage	60	V
V _{CEO}	Collector-Emitter Voltage	50	V
V _{EBO}	Emitter-Base Voltage	5	V
I _C	Collector Current	150	mA
P _C	Collector Power Dissipation	200	mW
R _{θJA}	Thermal Resistance From Junction To Ambient	625	°C/W
T _j	Junction Temperature	150	°C
T _{stg}	Storage Temperature	-55~+150	°C

ELECTRICAL CHARACTERISTICS (T_a=25°C unless otherwise specified)

Parameter	Symbol	Test conditions	Min	Typ	Max	Unit
Collector-base breakdown voltage	V _{(BR)CBO}	I _C = 100uA, I _E =0	60			V
Collector-emitter breakdown voltage	V _{(BR)CEO}	I _C = 0.1mA, I _B =0	50			V
Emitter-base breakdown voltage	V _{(BR)EBO}	I _E = 100uA, I _C =0	5			V
Collector cut-off current	I _{CBO}	V _{CB} =60V, I _E =0			0.1	uA
Emitter cut-off current	I _{EBO}	V _{EB} = 5V, I _C =0			0.1	uA
DC current gain	h _{FE}	V _{CE} = 6V, I _C = 2mA	130		400	
Collector-emitter saturation voltage	V _{CE(sat)}	I _C =100mA, I _B = 10mA			0.25	V
Base-emitter saturation voltage	V _{BE(sat)}	I _C =100mA, I _B = 10mA			1	V
Transition frequency	f _T	V _{CE} =10V, I _C = 1mA, f=30MHz	80			MHz

CLASSIFICATION OF h_{FE}

Rank	L	H
Range	130-200	200-400

Typical Characteristics

