

MBR4040CT THRU MBR40200CT

40A High Barrier Power Schottky Rectifiers - 40V-200V

Features

- Low power loss, high efficiency.
- High current capability
- High surge capability.
- Guardring for overvoltage protection.
- Low stored charge majority carrier conduction
- Silicon epitaxial planar chip, metal silicon junction.
- Lead-free parts meet environmental standards of MIL-STD-19500 /228
- Suffix "-H" indicates Halogen-free parts, ex. MBR4040CT-H.

Package outline

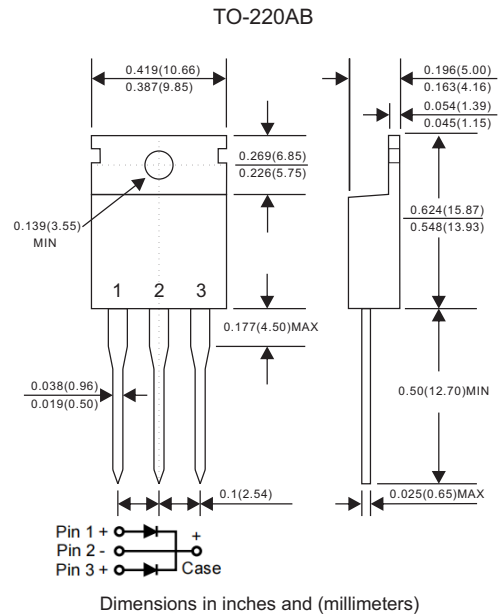

Mechanical data

- Epoxy : UL94-V0 rated flame retardant
- Case : JEDEC TO-220AB molded plastic body over passivated chip
- Lead : Axial leads, solderable per MIL-STD-202, Method 208 guaranteed
- Polarity: As marked
- Mounting Position : Any
- Weight : Approximated 2.10 gram

Maximum ratings (AT $T_A=25^\circ\text{C}$ unless otherwise noted)

PARAMETER	SYMBOLS	MBR 4040CT	MBR 4045CT	MBR 4050CT	MBR 4060CT	MBR 4080CT	MBR 40100CT	MBR 40150CT	MBR 40200CT	UNIT
Maximum repetitive peak reverse voltage	V_{RRM}	40	45	50	60	80	100	150	200	V
Maximum RMS voltage	V_{RMS}	28	31.5	35	42	56	70	105	140	V
Maximum DC blocking voltage	V_{DC}	40	45	50	60	80	100	150	200	V
Maximum average forward rectified current Per device	I_o	40								A
Peak forward surge current 8.3ms single half sine-wave(JEDEC method)	I_{FSM}	250								A
Operating junction temperature range	T_J	-55 to +150						-55 to +175		$^\circ\text{C}$
Storage temperature range	T_{STG}	-65 to +175								$^\circ\text{C}$

Electrical characteristics (AT $T_A=25^\circ\text{C}$ unless otherwise noted)

PARAMETER	SYMBOLS	MBR 4040CT	MBR 4045CT	MBR 4050CT	MBR 4060CT	MBR 4080CT	MBR 40100CT	MBR 40150CT	MBR 40200CT	UNIT
Maximum forward voltage per leg at $I_F=20\text{A}$	V_F	0.65		0.75		0.85		0.95		V
Maximum DC reverse current at $T_J=25^\circ\text{C}$ at rated DC blocking voltage at $T_J=125^\circ\text{C}$	I_R	0.1			0.01			15		mA mA

Thermal characteristics

PARAMETER	SYMBOLS	MBR 4040CT	MBR 4045CT	MBR 4050CT	MBR 4060CT	MBR 4080CT	MBR 40100CT	MBR 40150CT	MBR 40200CT	UNIT
Typical thermal resistance junction to case per leg	$R_{\theta JC}$	2.0								$^\circ\text{C}/\text{W}$

Rating and characteristic curves (MBR4040CT THRU MBR40200CT)

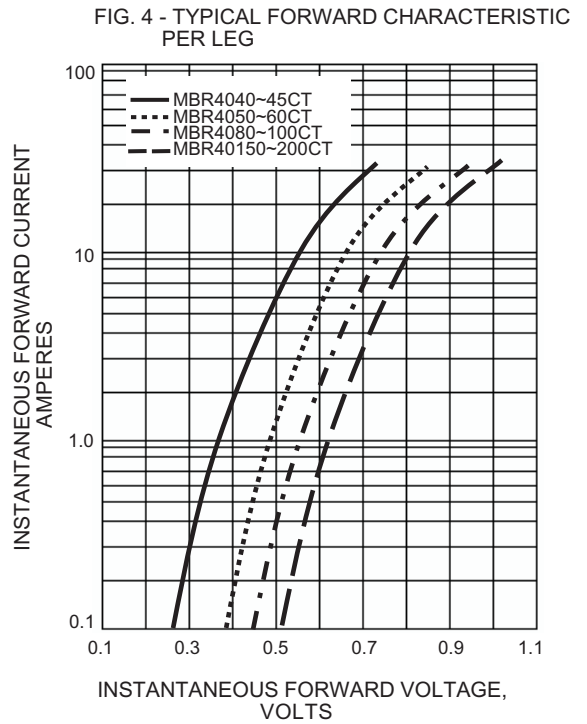
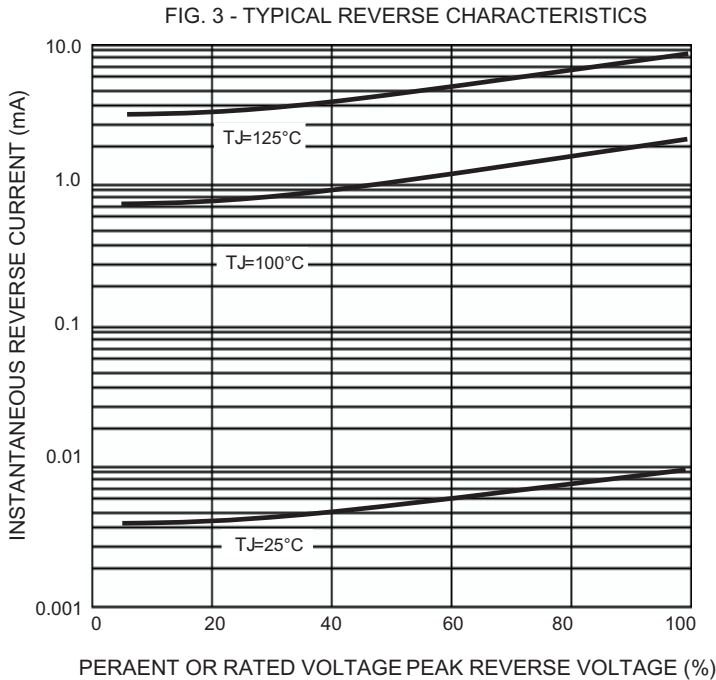
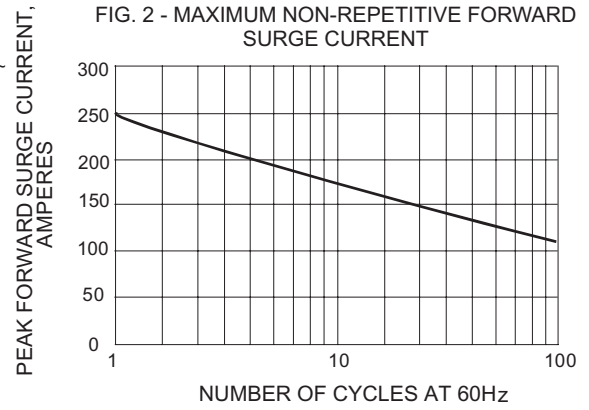
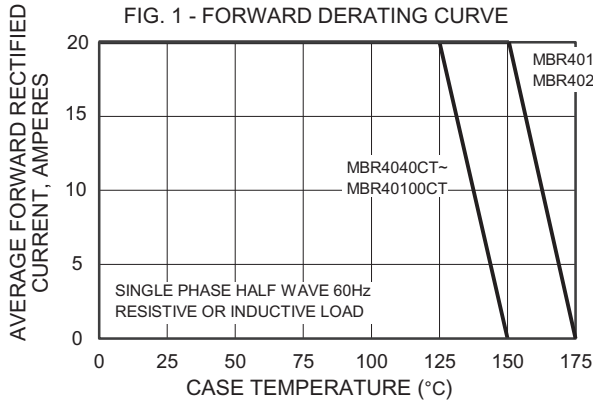

MBR4040CT THRU MBR40200CT

Pinning information

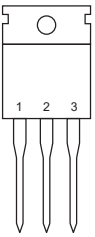
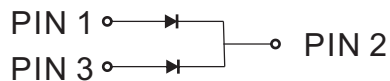
Pin	Simplified outline	Symbol
Pin1 anode Pin2 cathode Pin3 anode		

Marking

Type number	Marking code
MBR4040CT	MBR4040CT
MBR4045CT	MBR4045CT
MBR4050CT	MBR4050CT
MBR4060CT	MBR4060CT
MBR4080CT	MBR4080CT
MBR40100CT	MBR40100CT
MBR40150CT	MBR40150CT
MBR40200CT	MBR40200CT

Tube packing

PACKAGE	TUBE (pcs)	TUBE SIZE (m/m)	BOX (pcs)	INNER BOX (m/m)	CARTON SIZE (m/m)	CARTON (pcs)	APPROX. GROSS WEIGHT (kg)
TO-220AB	50	525*32*7.5	1,000	555*150*40	580*230*175	5,000	15.0

MBR4040CT THRU MBR40200CT

Suggested thermal profiles for soldering processes

1. Lead free temperature profile wave-soldering

