

P10V45

10A 45V MOS Schottky Rectifier

Major ratings and characteristics

Characteristics	Values	Units
$I_{F(AV)}$ Rectangular Waveform	10	A
V_{RRM}	45	V
$V_F@ 10A, T_j=125^\circ C$	0.39	V, typ.
T_j Operating Junction Temperature	-65 to +150	$^\circ C$

Features

- Ultra Low Forward Voltage Drop
- Reliable High Temperature Operation
- Softest, fast switching capability
- 150 $^\circ C$ Operating Junction Temperature
- Lead Free Finish, RoHS Compliant
- Green Molding Compound (No Br, Sb)

Typical Applications

Device optimized for ultra-low forward voltage drop to maximize efficiency in Power Supply applications

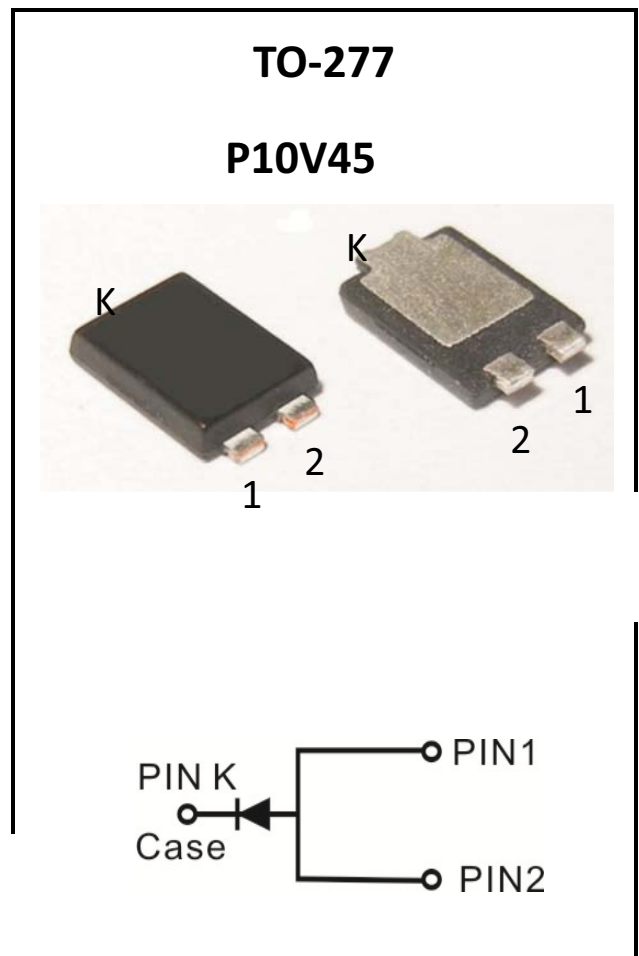

1. Characteristics

Maximum Ratings Characteristics

($T_A = 25\text{ }^\circ\text{C}$ unless otherwise specified)

Parameter	Symbol	Values	Units
DC Blocking Voltage	V_{RM}	45	Volts
Working Peak Reverse Voltage	V_{RWM}		
Peak Repetitive Reverse Voltage	V_{RRM}		
Average Rectified Forward Current Per device	I_o	10	Amps
(Rated VR-20Khz Square Wave) - 50% duty cycle			
Peak Forward Surge Current - 1/2 60hz	I_{FSM}	275	Amps
Peak Repetitive Reverse Surge Current (2uS-1Khz)	I_{RRM}	2	Amps
Typical Thermal Resistance	$R\theta_{JA}$	72	$^\circ\text{C} / \text{W}$
Thermal Resistance junction to Ambient Note (1)			
Thermal Resistance junction to Ambient Note (2)			
Maximum Rate of Voltage Change (at Rated VR)	dv/dt	10000	V/uS
Operating Junction Temperature	T_J	- 65 to +150	$^\circ\text{C}$
Storage Junction Temperature	T_{STG}	- 65 to +150	

Electrical Characteristics - (per leg)

($T_A = 25\text{ }^\circ\text{C}$ unless otherwise specified)

Parameter	Test Conditions	Symbol	Typ.	Max.	Units
Instantaneous Forward Voltage	IF = 10 A	VF*	---	0.47	Volts
			$T_J = 125\text{ }^\circ\text{C}$	0.39	
Instantaneous Reverse Current	At V_{RM}	IR*	---	300	μA
			$T_J = 125\text{ }^\circ\text{C}$	---	75

* Pulse width < 300 uS, Duty cycle < 2%

Note 1. FR-4 PCB, 2 oz Copper. Minimum recommended pad layout

Note 2. Polyimide PCB, 2 oz Copper. Cathode pad dimensions 18.8x14.4mm , Anode pad dimensions- (5.6x14.4mm)

2. Characteristics Curves

Ratings and Characteristics Curves

($T_A = 25^\circ\text{C}$ unless otherwise specified)

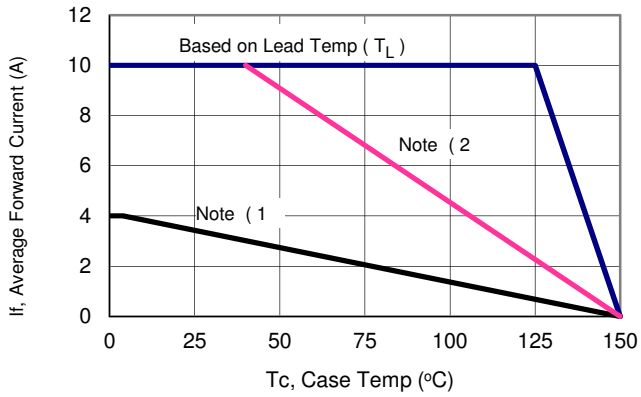

Figure 1: Current Derating, Case

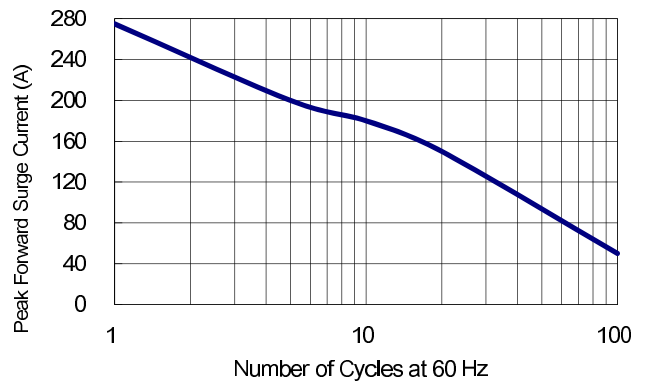

Figure 2: Maximum Repetitive Surge Current

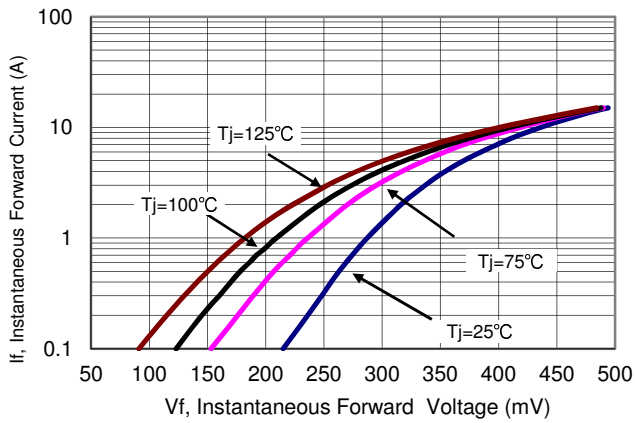

Figure 3: Typical Forward Voltage

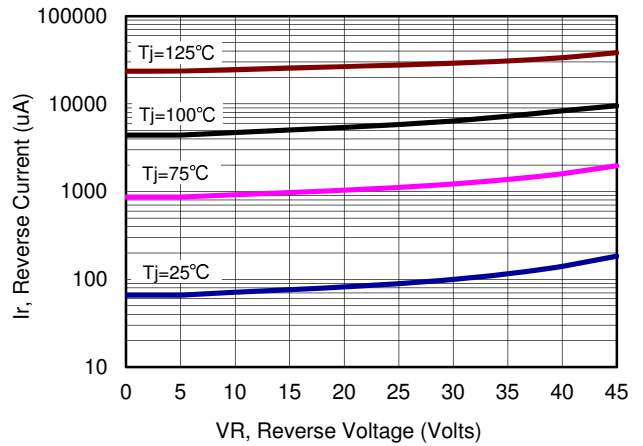

Figure 4: Typical Reverse Current

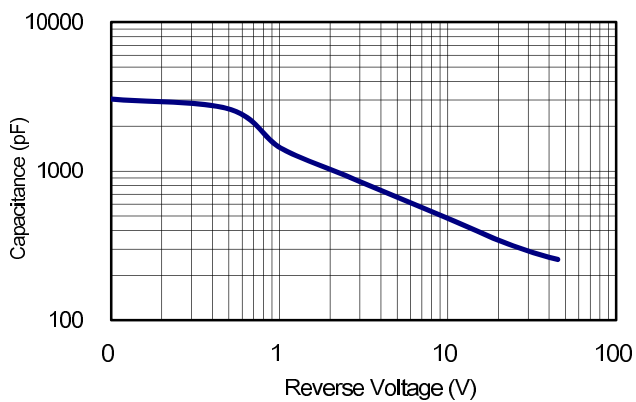
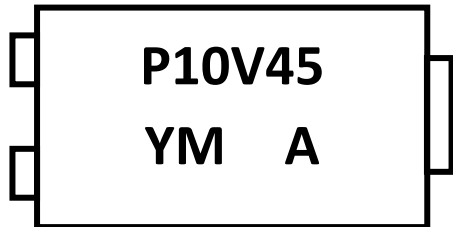

Figure 5: Typical Junction Capacitance

3. Marking information

Top Marking Rule



P10V45 = Product Type Marking Code

YM = Date Code

Y = Last one digits of year

M = Month code

A = Assembly Code

4. Package information

Suggested Package Outline Dimensions millimeters

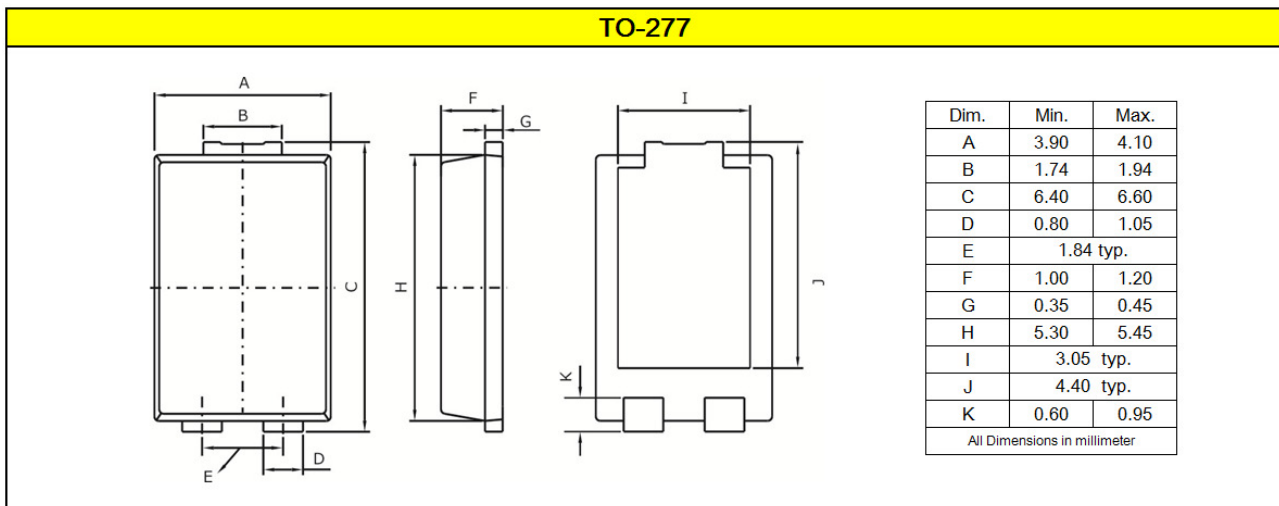

Mounting pad Outline Dimensions millimeters

